

Installation and Operating handbook

IBD420 C to L Band Downconverter

Handbook Issue 2.00, 12th august 2008



EN 55022 CLASS B
EN 50082-1
EN 60950



PEAK COMMUNICATIONS Ltd.
Kirklees House, 22 West Park Street
Brighouse, West Yorkshire
HD6 1DU, England

Phone 01484 714200
Fax 01484 723666

**IMPORTANT NOTE: THE INFORMATION AND SPECIFICATIONS
CONTAINED IN THIS DOCUMENT SUPERCEDE ALL PREVIOUSLY
PUBLISHED INFORMATION CONCERNING THIS PRODUCT**

PEAK COMMUNICATIONS Ltd maintains a continuing programme of product improvement and therefore reserves the right to change specifications without notice

INTRODUCTION

The IBD420 C to L Band Downconverter is a high grade unit which can be applied to many situations where good stability and phase noise is required.

The unit consists of an RF strip which is a filter, amplifier and mixer stage and a control PCB to monitor the system and provide a stable reference for the Local Oscillator.

The unit is housed in 19 inch 1'U' high chassis, suitable for rack mounting, is 400 mm deep and may be fitted with rack slides if required.

SPECIFICATION

Input range:	3.40GHz to 4.20GHz
Input connector:	SMA female
Input impedance:	50Ω
Nominal gain:	30 dB
Input maximum aggregate power	-40dBm
Output Nominal Frequency:	950 MHz to 1750 MHz Inverted spectrum
Local Oscillator:	5.15 GHz
1 dB Compression point	+8 dBm output
3rd Order Intercept point	+18 dBm min
Output phase noise (when driven by a signal with phase noise 10 dB better than these figures)	-75 dBc/Hz @ 100 Hz -92 dBc/Hz @ 1 kHz -100 dBc/Hz @ 10 kHz -107 dBc/Hz @ 100 kHz -125 dBc/Hz @ 1 MHz
Output connector:	SMA female
Output Impedance:	50Ω
In-band spuri:	<-80dBm non carrier related <-75dBm carrier related
External Reference	10 MHz, 0dBm (optionally 5 MHz)
Alarms	Separate Normally Closed relay contacts for out of lock LO, power supply and amplifier
Temperature:	-20°C to 60°C operating, -40°C to 85°C storage
Relative humidity:	0 to 90% operating, 0 to 95% storage
Housing	19 inch 1'U' high chassis 400mm deep
Power requirements	230 Volt AC ± 10% or 115 Volt ± 10 % selectable. 100 watt max. (fused 2 x 1 amp)

EMC AND SAFETY

EMC

The IBD420 C Band Downconverter has been designed to comply with the following standards;

Emissions : EN 55022 Class B; Limits and methods of measurement of radio interference characteristics of Information Technology Equipment.

Immunity : EN 50082 Part 1; Generic immunity standard, part 1: Domestic, commercial and light industrial environment.

The equipment must be operated with its lid on at all times. If it is necessary to remove the lid for routine servicing or fault finding then it is essential that the lid is fitted back correctly before normal operation.

For the Alarm and Remote Control data interfaces all 'D' type connectors must have grounding fingers on the plug shell to guarantee continuous shielding. The back-shells must comply to the requirements of VDE 0871 and FCC 20708, providing at least 40 dB of attenuation from 30 MHz to 1 GHz.

Connecting cables must be of the shielded type

Operation of the equipment in a non standard manner will invalidate compliancy to these standards.

Safety

To ensure safety of operator the IBD420 C Band Downconverter unit has been designed to comply with the following safety standard;

EN 60950 Safety of information technology equipment, including electrical business machines.

Before operation the user must ensure that the installation complies with the information given.

The equipment is designed to operate in a static 19 inch rack system conforming to IEC 297-2. Operation of the equipment in transportable vehicles equipped with the means of providing a stable environment is permissible. Operation of the equipment on board vehicles, ships or aircraft without means of environmental conditioning will invalidate the safety compliancy; please contact the factory for further advice. Operation of the equipment in an environment other than that stated in the specifications will also

invalidate the safety compliancy. The equipment must not be operated above 2000 metre altitude, extremes of temperature; excessive dust, moisture or vibration; flammable gases; corrosive or explosive atmospheres.

Installation

The equipment is classified in EN 60950 as a pluggable equipment class A for connection to the mains supply, as such it is provided with a mains inlet cord suitable for use in the country of operation. In normal circumstances this will be of an adequate length for installation in the rack. If the mains cord proves to be too short then any replacement must have a similar type fuse (if fitted) and be manufactured to similar specification: check for HAR, BASEC or HOXXX-X ratings on the cable. The connector ends should be marked with one of the following : BS1636A (UK free plug 13 amp); BSI, VDE, NF-USE, UL, CSA, OVE, CEBEC, NEMKO, DEMKO, SETI, IMQ, SEV and KEMA-KEUR for the IEC 6 amp free socket. Schuko and North American free plugs must have similar markings.

The installation of the equipment and the connection to the mains supply must be made in compliance to local or national wiring regulations for a category II impulse over voltage installation. The positioning of the equipment must be such that the mains supply socket outlet for the equipment should be near the equipment and easily accessible or that there should be another suitable means of disconnection from the mains supply.

The equipment is designed to operate from a TN type power supply system as specified in EN 60950. This is a system that has separate earth, line and neutral conductors. The equipment is not designed to operate with an IT power system which has no direct connection to earth.

UNIT DESCRIPTION

Front panel indicator

The IBD420 C Band Downconverter front panel has 5 indicator lights which are

STATUS	Normally lit GREEN but will turn RED with any internal failure causing an alarm
ON LINE	Lit GREEN only when unit selected or external adapter is fitted
POWER	Lit GREEN when status of 5 Volt supply is OK
LOCKED	Lit GREEN when the Downconverter is correctly locked on frequency
EXT REF	Lit YELLOW if 10MHz External Reference is in use

An Internal alarm is caused by an out of lock Local Oscillator, power supply less than 200 volts or the amplifier failure

Rear panel connections

C BAND INPUT	Input at C Band in the frequency range 3.40GHz to 4.20GHz. Maximum input should not exceed -40dBm
L BAND OUTPUT	Output in the frequency range 950 to 1750 MHz.. Output is an inverted spectrum, Calculation of the relative frequencies at C and L band is $5.15 \text{ (LO) minus C Band frequency} = \text{L band frequency}$
COUPLED OUTPUT	This output is from the -20dBc coupler mounted on the output of the Input filter. This should be terminated if not in use. This is a non-standard feature.
EXT INTERFACE	Digital interface with the following signals

Ground	1	9	PSU OK - N/Closed
PSU Common	2	10	LO OK - N/Closed
LO Common	3	11	Amp OK - N/OPEN
Amp common	4	12	Unit select input
Not used	5	13	Not used
Audio Alarm enable	6	14	Not used
Audio Alarm enable	7	15	Not used
Not used	8		

Notes

To disable the internal audible alarm remove short from pins 6 and 7

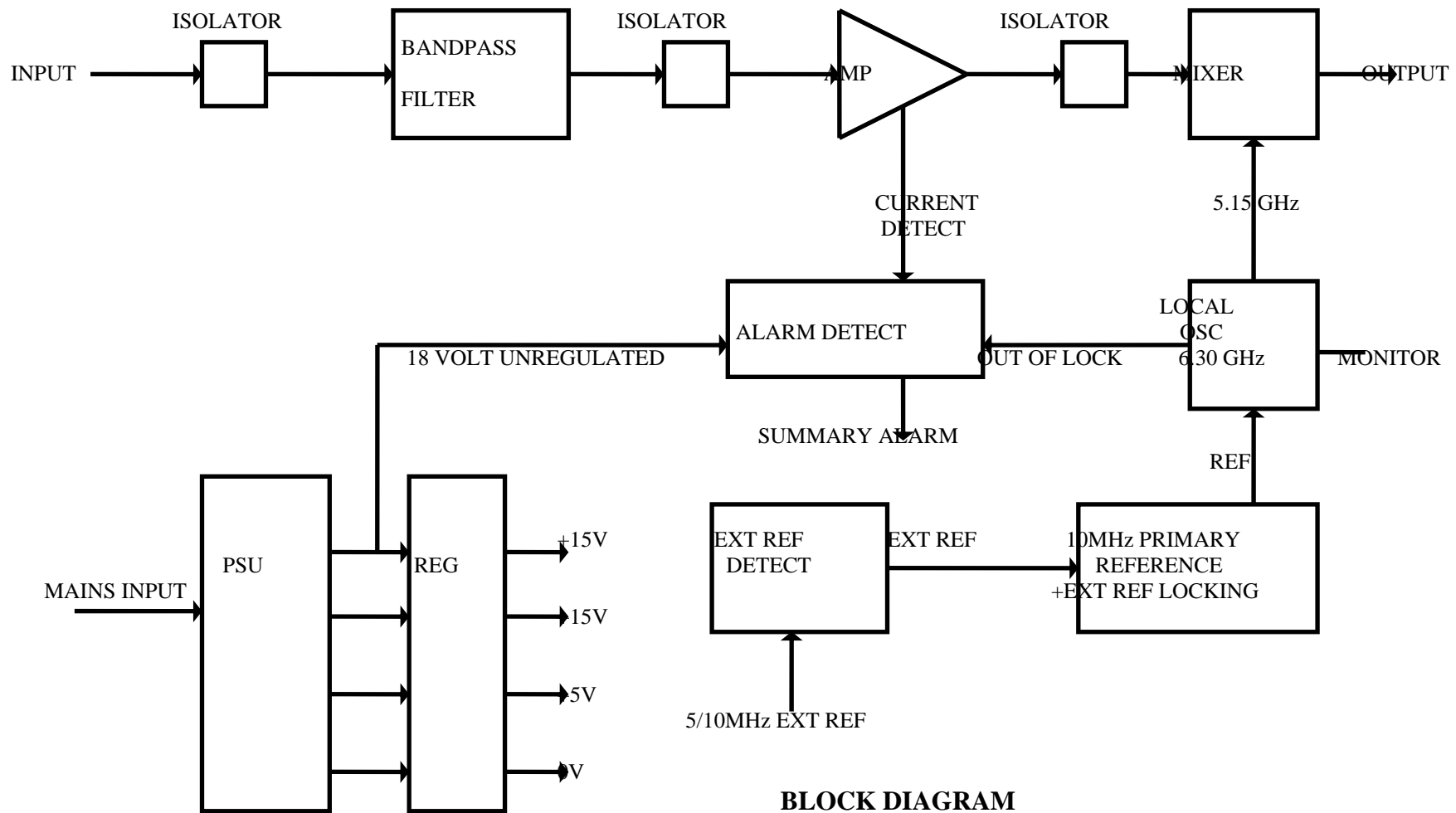

**BLOCK DIAGRAM
IBD420 C to L BAND DOWNCONVERTER**

OPERATION

Ensure the voltage selector on the rear of the panel is set to the correct setting. The unit is factory set at 230 Volts

On switching on the unit the STATUS indicator on the front of the unit should turn GREEN if all is OK.

If an alarm condition continues to show check alarm conditions on the rear panel

Connect the signal in to the INPUT SMA type connector taking note of the power of the signal being input. Care should be taken if the equipment connected to this socket has any DC present as the input to the unit has an isolator fitted which has a low DC tolerance.

The input SMA connector is rated to 18GHz and is a precision connector. DO NOT OVERTIGHTEN. Ensure a good quality connector is used to avoid poor contacts.

Output from the unit at L Band is from the output marked OUTPUT.

Alarms

The PSU and LO failure relay contacts used are open when the unit is not powered or has a fault. In normal operating conditions the relays are energized and the contacts are closed.

The Amplifier failure relay contacts used are closed when the unit is not powered or has a fault. In normal operating conditions the relays are not energized and the contacts are open.

The PSU and LO alarms on the D type connector can be chained to give a summary alarm. A typical configuration could be to link pin 3 to pin 9 then connect a piece of twin wire to pins 2 and 10. In normal conditions these 2 wires should show continuity.

Typically if pins 1 and 2 are joined in addition to the above an alarm indication would be a non grounding signal

Alarms are due to the following reasons

1. 5 Volt rail drops to 0 Volts. The unit will indicate a PSU failure.
2. DRO is out of lock. The unit will alarm when the DRO phase volts drop below 2 Volts or exceed 12 Volts.
3. Amplifier not taking any current.

Internal adjustments

Internal frequency reference adjust (factory set) is a potentiometer on the PCB